

## Micro Gear Liquid Pump Range

### Overview : High Pressure Pump, Self Priming, Stepper Motor Control

The MG2000-STEP range of pumps deliver accurate and consistent flow at pressure. They are suitable for low or high viscosity liquids and are self-priming. Constructed from precision CNC machined components with wetted parts of stainless steel, PEEK, polyacetal and PTFE.

The MG2000 can be used with all common liquids and resists most chemicals and solvents.

Machined with two threaded ports that are fitted as standard with two tubing connector options ; stainless steel threaded tubing connectors for quick and easy to connection to tubing, or for directly mounting to your manifold. Flow is reversible.

### The MG2000-STEP Pump

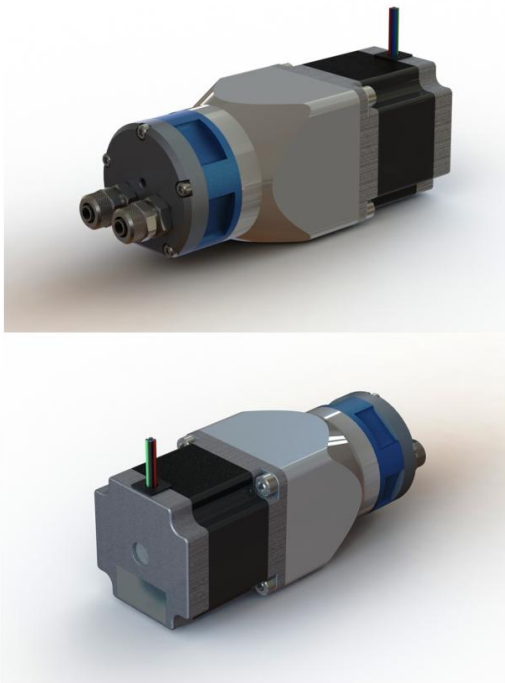

**Note.**

The MG2000-STEP pump utilizes a high performance, accurate Stepper Motor drive technology. These motors require a separate controller to operate and TCS Micropumps offer the EQi-ST range of controllers for this purpose.

### Typical Applications

- Medical devices
- Precision Flow
- Dosing applications

### Features

- High pressure capability
- Self-priming
- High and low viscosity liquids
- Smooth almost pulseless flow
- Reversible flow
- Wide range of chemical resistance

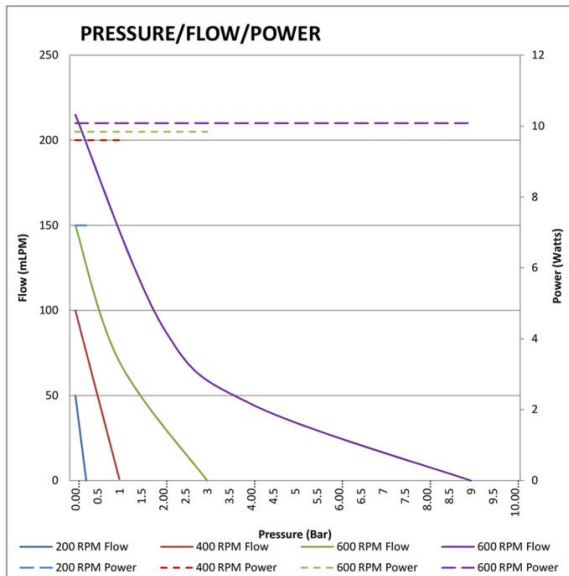
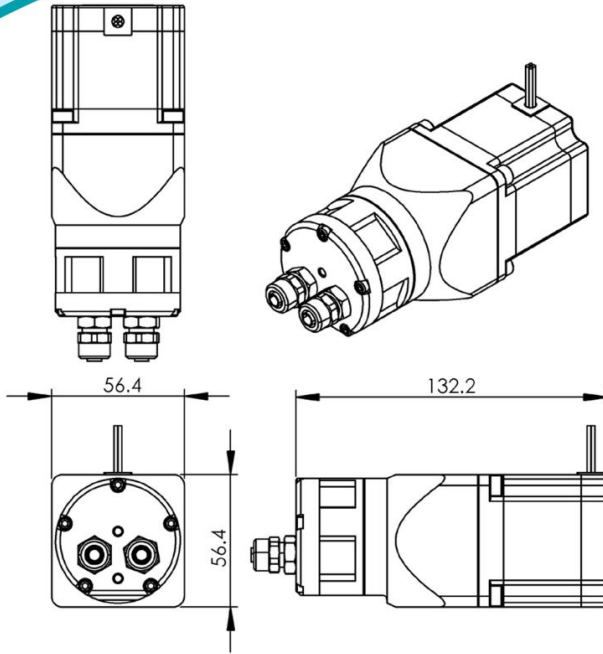

## Materials

### Wetted Parts

- Anodised 6000 Series Aluminium
- 316 Stainless Steel
- Viton
- PEEK
- PTFE
- Polyacetal
- Nickel

### Performance Data

- Small Size                      57 x 57 x 132mm
- Weight                              340 g
- Operating Temp                -20 to 100 deg C
- Smooth Pulseless Flow
- IP Rating - Standard pumps    IP62
- Noise Levels                      15DB  
Measured at a distance of 1m with a 50dB ambient noise level
- MTBF Stock Pumps              10,000hrs  
Special Variants available to order    >100,000hrs

Sold in North America by:  
**Servoflo Corporation**  
 75 Allen Street Lexington, MA 02421  
 Tel: 781-862-9572  
[www.servoflo.com](http://www.servoflo.com) / [info@servoflo.com](mailto:info@servoflo.com)

All tests conducted pumping TCS Coolant and using an EQi-ZD10 motor controller.  
 Note for maximum pump life you should not subject the MG2000-STEP to pressures exceeding 10 bar