

microComponents<sup>m</sup>

# Operating Manual for Controller mp-Highdriver

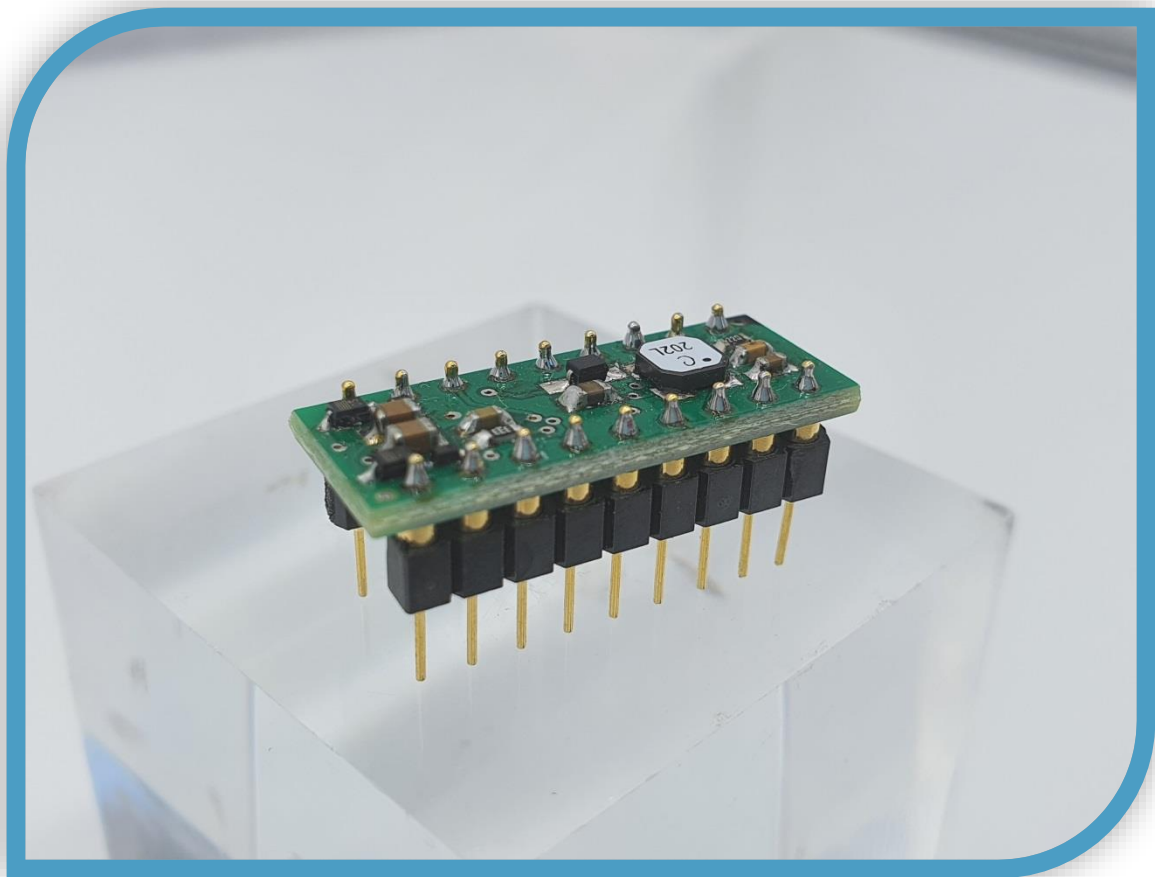

## Content

Operating Manual for Controller mp-Highdriver.....	1
General.....	3
Declaration of conformity.....	3
Description of functions.....	3
Proper use.....	4
Intended purpose.....	4
Misuse.....	4
Staff selection and qualification .....	4
About this operating manual .....	4
The mp-Highdriver controller.....	5
Technical specifications mp-Highdriver .....	5
Electrical Characteristics.....	6
Pin description .....	7
Connecting the micropump with the mp-Highdriver .....	8
Examples of circuiting the mp-Highdriver.....	9
Operation with fixed settings.....	9
Operation with variable settings via external components.....	9
Operation with variable settings via microcontroller .....	10
Operation with variable settings via I <sup>2</sup> C-Interface.....	11



## General

This operating manual contains all necessary instructions for the installation, commissioning, operation and maintenance of the mp-Highdriver. The manual is intended to help you achieving optimal results in a short time and shall also assist avoiding possible sources of errors. The operating manual of the other controllers, micropumps and the accessories are available separately.

The products have been designed with state-of-the-art technology and in accordance with all relevant safety regulations. However, a risk of damage to the units, other property, the operator and/or other persons cannot be fully excluded.

Always ensure that specialized and trained personnel will comply with the following general instructions.

Therefore, please keep this manual and hand out copies as required.

Bartels Mikrotechnik GmbH rejects any responsibility for damages to persons or property resulting from non-compliance with the instructions in this manual. In this case all warranties shall be void.

### Declaration of conformity

Bartels Mikrotechnik GmbH declares that the products are compliant to the RoHS directive 2011/65/EU. The controller complies with the requirements of EMV 2014/30/EU and CE markings have been affixed to the devices. Additionally, the controllers are also compliant to the EU Low Voltage Directive 2014/35/EU.

### Description of functions

The micropumps have been developed for the transport of gases or liquids. The controllers have been developed for operating the micropumps. Bartels Mikrotechnik can assume no liability for damages resulting from the pump media. This applies especially for hazardous fluids.

The pumps must be operated with Bartels Mikrotechnik electronics. Bartels Mikrotechnik GmbH cannot guarantee the proper work of the units with customer specific electronics. If other controllers than the ones from Bartels Mikrotechnik are used, Bartels Mikrotechnik disclaims any warranty.

**Moreover, please note that components of the controller and pump are operating with high-voltage.** Therefore, persons wearing pacemakers are recommended to avoid the operating system.

Bartels Mikrotechnik assumes no liability for abnormal handling, improper or negligent use of the micropump and the controller that is not conform to the specified purpose of the system. This applies especially for micropump controllers, components and systems of other manufacturers, which have not been certified by Bartels Mikrotechnik.

We guarantee that the micropumps comply with the actual state of scientific and technical knowledge hence the operational risks are limited to a minimum.

**Do not open the housing of the micropump and the controllers.** In those cases, Bartels Mikrotechnik cannot issue a guaranty anymore. Please keep this manual safe and give a copy to all users.



## Proper use

### Intended purpose

The micropump is intended for pumping liquids or gases with varying flow rates controlled by the electronics. The controllers are intended for operating the micropumps. Any other use of the micropump or controller unit is deemed improper.

Do not make any modifications or extensions to the pump or controller without the prior written consent of the manufacturer. Such modifications may impair the safety of the unit and are prohibited! Bartels Mikrotechnik GmbH rejects any responsibility for damage to the unit caused by unauthorized modifications to the pump and risk and liability are automatically transferred to the operator.

### Misuse

The use of liquids, which may alone or in combination create explosive or otherwise health-endangering conditions (including vapors) is not permitted.

### Staff selection and qualification

All work in connection with the installation, assembly, commissioning/decommissioning, disassembly, operation, servicing, cleaning and repairing of the pump and the controller must be carried out by qualified, suitably trained and instructed personnel. Work on electrical components and assemblies must be carried out by personnel with the necessary qualifications and skills.

### About this operating manual

Warnings and important notes are clearly identified as such in the text. The relevant text sections feature a specific sign. However, this icon cannot replace the safety instructions. Therefore, carefully read all safety instructions in this manual. Warnings and important notes in this text are highlighted as shown below, according to the severity of the damage that might result from non-compliance.

 **DANGER**

Danger indicates a hazard with a high level of risk that, if not avoided, will result in death or serious injury.



## The mp-Highdriver controller

The mp-Highdriver is a small, easy to use driving circuit developed for the micropumps of the mp6-series especially the mp6-liq as it delivers a 200Hz signal at full amplitude as a default signal. It generates amplitudes up to 250 Vpp from a 3-5 V DC supply.

Its low power consumption makes it ideal for battery powered handheld devices or even solar powered devices.

The module can be integrated into a PCB design as an 18 pin DIL package.

The build-in interface allows the user to adapt frequency, amplitude and signal-shape to its application by the use of a few additional components or a microcontroller.

In order to locate Pin 1, please refer to the following figure. The pin is marked with a colored spot or triangular marking on the corner of the PCB.

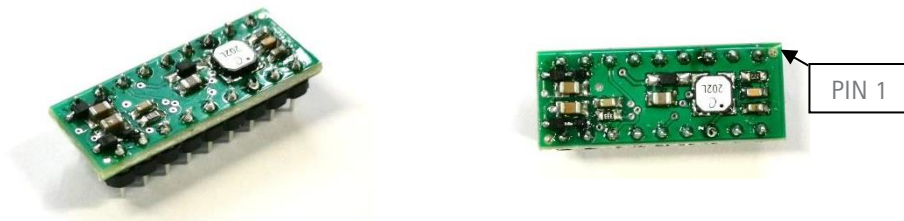

### Technical specifications mp-Highdrier

mp-Highdrier controller	Order code: mp-Highdriver
The mp-Highdriver controller drives the micropump at adjustable performance in a package similar to an integrated circuit. It enables integration into system electronics or on a PCB.	
Dimensions	10,16 x 25,40 x 2.82 mm 0.4 x 1.0 x 0.11 in
Adjustable parameters	amplitude, frequency, wave form
Amplitude range	10 – 250 Vpp
Frequency range	50 – 800 Hz
Signal form	sine, rectangular, trapezoid
Power supply	2.7 – 5.5 VDC
Pin arrangement	DIL 18; horizontal 2.54 mm, vertical 7.62 mm



## Electrical Characteristics

Parameter	Symbol	Conditions	Min	Typ.	Max	Unit
Supply voltage	VDD		2.5		5.5	V
Average current consumption	IDD	VDD = 5 V		40		mA
Setting range AMPLITUDE			0.5		1.3	VDC
min. voltage at pump	V <sub>pump</sub>	AMPLITUDE = 0.5 VDC		10		V <sub>pp</sub>
max. voltage at pump (1)	V <sub>pump</sub>	AMPLITUDE = 1.25 VDC	250	260	270	V <sub>pp</sub>
Frequency output	F	VDD = 5 V (Default)		200		Hz
Digital Low-Signal					0	V
Digital High-Signal			2			V
Input current AMPLITUDE			1		3	μA
Operating current during Shutdown Mode				1.6		μA

1 The signal output is determined by internal components and is subject to tolerances



Pin description

Pin	Name	Function
1,2,17,18	NC	This pins should not be connected and left floating
3	GND	Ground
4	CLK	Predefined clock signal. Frequency will be set to the nominal 200 Hz, when this pin is connected to CLK_INT (see image "Schematic 1" in chapter 0). It is also possible to connect an external clock signal with a <u>quadruplicated</u> frequency of the micropumps frequency.
5	CLK_INT	When connected to CLOCK the frequency is set to 200 Hz.
6	AMP	The amplitude can be set with an analogue voltage between 0.5 V to 1.3 V.
7	A0	Address Input 0. Address inputs allow up to four connections on one common bus. Connect A0 to GND or VDD.
8	P1+	Piezo actuator 1, positive electrode (see page 9)
9	P1-	Piezo actuator 1, negative electrode (see page 9)
10	P2-	Piezo actuator 2, negative electrode (see page 9)
11	P2+	Piezo actuator 2, positive electrode (see page 9)
12	A1	Address Input 1. Address inputs allow up to four connections on one common bus. Connect A1 to GND or VDD.
13	SCL	Serial-Clock Input. SCL requires an external pullup resistor.
14	SDA	Open-Drain, Serial Data Input/Output. SDA requires an external pullup resistor.
15	/RESET	If the I2C-Bus is to be used, the internal processor has to be disabled by applying GND to this pin. Otherwise connect this pin to VDD for normal operation.
16	VDD	Input Supply voltage



IC1

MP6-XOEM



### Connecting the micropump with the mp-Highdriver

The micropumps of the mp6-series can be connected with the mp-Highdriver via a FCC connector. More information concerning this connector and the pin layout of the micropump can be found in manual of the micropump mp6-series.

 **DANGER!**

The output of the mp-Highdriver carries high voltage!

Only plug in the micropump when the mp-Highdriver controller is unpowered  
or switched off





## Examples of circuiting the mp-Highdriver

### Operation with fixed settings

The mp-Highdriver can operate the micropumps of the mp6-series without further external components. In this case, frequency and amplitude to the micropump are predefined to 250 Vpp and 200 Hz by the internal circuit.

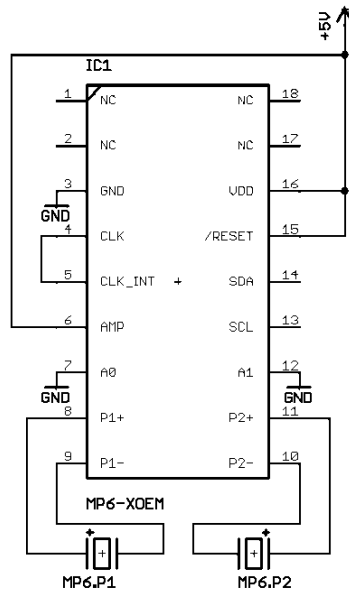

Schematic 1: Predefined amplitude of 250 Vpp and frequency of 200 Hz by internal circuit.

### Operation with variable settings via external components

In this example, amplitude to the micropump will be defined by external components. The amplitude can be varied in the range from 0 Vpp to 250 Vpp.

Using a voltage divider it is possible to set the amplitude with only two additional resistors. See image "Schematic 2" below for an example. First picture shows two resistors generating the reference voltage for the AMP-pin. The voltage at the AMP-pin can be calculated with this formula:

$$V_{AMPLITUDE} = V_{DD} \cdot \frac{R1}{R1 + R2}$$

As an alternative an appropriate potentiometer can be used to adjust the reference voltage. On the second picture a potentiometer and an offset resistor are used to generate the reference voltage for the AMP-pin.



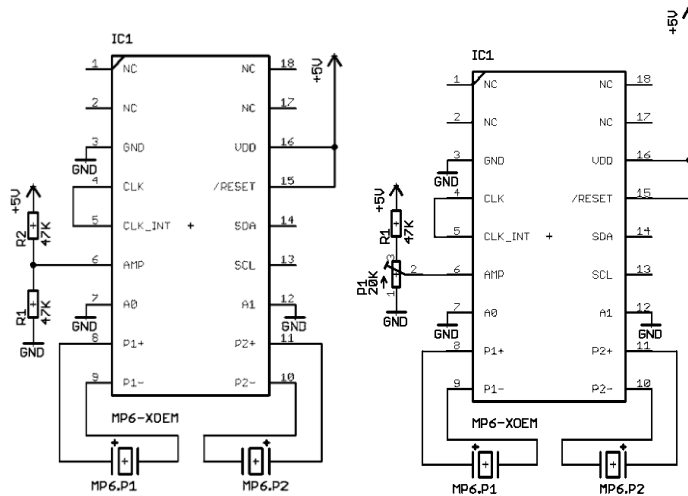

Schematic 3: Defining amplitude with external components.

The relation of the voltage at the AMP-pin vs. the output voltage is shown in the picture below. It shows a gain of approx. 200:1 between reference voltage and output voltage.

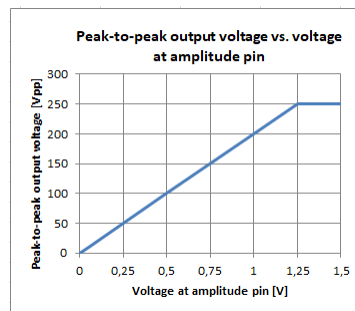

OEM-Behavior 1: Output voltage changed with external components.

Unlike the mp6-OEM, the frequency on the mp-Highdriver cannot be selected via external capacitor. This can only be done by supplying a clock signal to the CLK-pin which is shown in the next chapter.

### Operation with variable settings via microcontroller

Using a microcontroller to operate the micropump, a square wave signal (0V-VDD; 50% duty-cycle) with four times the desired output frequency has to be supplied to the CLK Pin.

The amplitude can be set with an analog voltage between 0 V and 1.25 V. Voltages above 1.25V up to VDD are allowed and keep the output voltage at maximum.

For minimizing the power consumption, the mp-Highdriver can be switched off. To do this, apply a 0V signal to the AMP-pin.



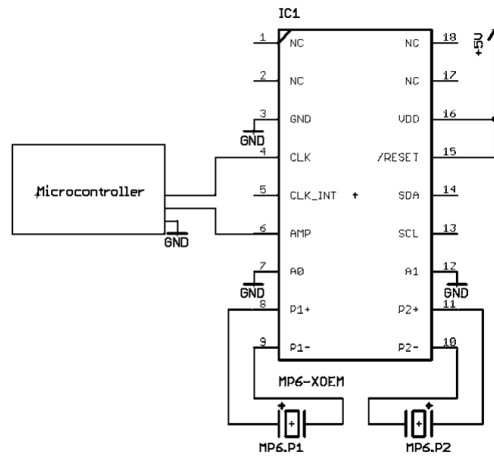

Schematic 4: Controlling settings via microcontroller

### Operation with variable settings via I<sup>2</sup>C-Interface

The mp-Highdriver can also be operated using the I<sup>2</sup>C-Interface. Using this interface all the features of the chip can be accessed. The functionality and procedures are identical to the mp6-QuadOEM. A complete interface and protocol description can be found in the manual of the mp6-QuadOEM on our download page.

To activate the I<sup>2</sup>C-Interface the onboard processor has to be deactivated by tying the reset pin to Ground. Select a desired slave-address connecting pins A0 and A1 to either VDD or GND and interface the chip through the I<sup>2</sup>C-pins SDA and SCL. Both need an external pullup resistor (47K recommended) tied to VDD. (There are no pullup resistors onboard the mp-Highdriver)

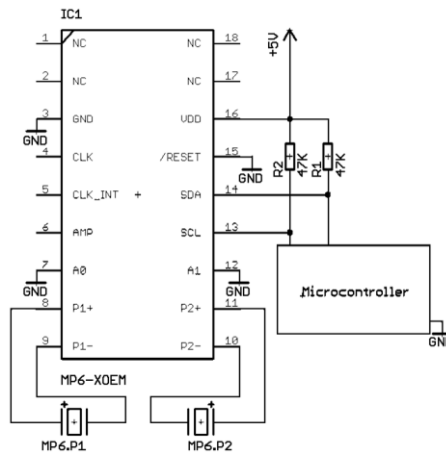

Schematic 5: Controlling settings via I<sup>2</sup>C

All values are approximate and no guarantee of specific technical properties.

Changes in the course of technical progress are possible without notice.



**Contact Data:**

Bartels Mikrotechnik GmbH  
Konrad-Adenauer-Allee 11  
44263 Dortmund Germany  
[www.bartels-mikrotechnik.de](http://www.bartels-mikrotechnik.de)  
[info@bartels-mikrotechnik.de](mailto:info@bartels-mikrotechnik.de)  
Tel: +49-231-47730-500  
Fax: +49-231-47730-501

**Visit our Website**

[www.bartels-mikrotechnik.de](http://www.bartels-mikrotechnik.de)

**for further information on applications.**

**Tutorials and helpful answers to frequently asked questions can be found in our FAQ**

[www.bartels-mikrotechnik.de/en/faq-english/](http://www.bartels-mikrotechnik.de/en/faq-english/)

**or on our YouTube channel**

<https://www.youtube.com/user/BartelsMikrotechnik>

**Social Media:**

